

Micro-Filler

Product Spec Sheet

Precision Auger filler for food, pharmaceutical, chemical, cosmetic and household products.



The Micro-Filler fills powder, granular and past products into all types of containers.

Features of the Micro-Filler:

- Easy to operate; low maintenance; long service life.
- Variable speed auger and agitator drive system; permanent magnet; TENV motor with HD gear reducer.
- 20 liter stainless steel hopper mounted with quick disconnect hand knobs. Hopper is positioned with locating pins for convenient removal and positive assembly.
- Stainless steel NEMA 4 electrical enclosure and IP68 controls.
- Tooling for your designated product and container.
- Adjustable height container support platform.
- Single cycle footswitch to actuate the fill cycle.
- Heavy Duty casting base with adjustable leveling pads (optional Casters).
- Optional fill head height adjustment.
- Can be disassembled and cleaned in minutes.
- Fully adjustable fill range.
- Exceptional customer support for service and parts.
- Made with Pride in the USA

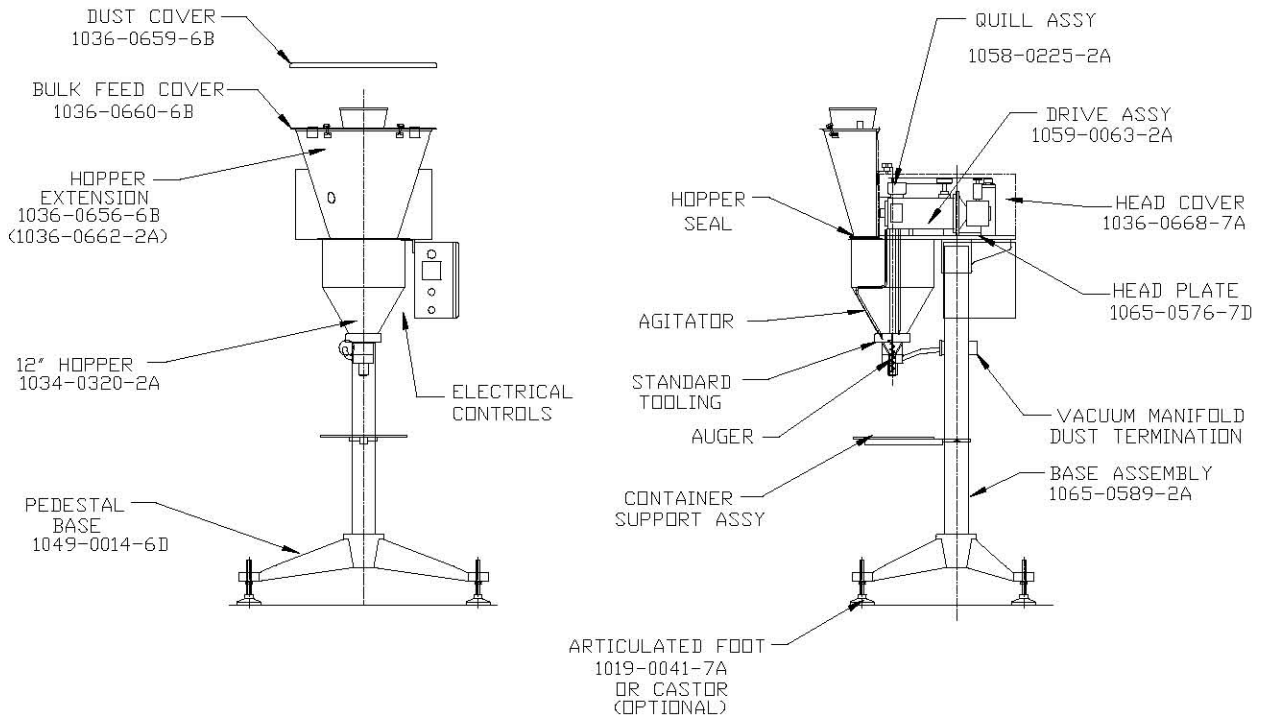

Specifications

- Fill Rate: 2 to 20 Fills Per Minute (50 Grams)
- Fill Accuracy: $\pm 1\%$ of net weight
- Fill Range: $\frac{1}{2}$ gram to 1000 gram per container
- Time for Cleanup: 30 minutes
- Power Requirements: 120V, 220V; 50/60 HZ; 1 Phase

BUSCH MACHINERY

Over 30 Years of Applications Expertise

800-840-9573 INTL 520-777-3360

EMAIL: sales@busch-machinery.com

WEBSITE: <http://busch-machinery.com>