

nano-Filler

PRODUCT TECHSHEET



The nano-Filler features:

- Touch-screen control with 99 product memory
- Bench mount design
- Stainless steel construction
- Quick release auger and hopper removal
- Production rates from 10-100 doses per minute

The nano-Filler is designed for the precision dosing of powders and granules, 25 mg- 10 gram per dose.

The nano-Filler features a precise, servo driven auger that ensures optimum control of fill accuracies; separate DC-Variable speed agitator drive to control product consistency; and off-the-shelf PLC with touch-screen interface for simple adjustment of all filler parameters.

This versatile filler can be supplied as a bench mount semi-automatic unit or fully automatic with container handling system for high speed production. The nano-Filler can also be integrated with a balance for net weigh fill operations or with checkweigher to feedback and adjust the auger.

The sanitary design features 304 stainless steel construction as standard. 316L and autoclavable class 100 designs are also available.

nano-Filler

technical specifications

electric and controls

Display:	Touch Screen Interface
Electrical Requirements:	120/220 volt; 1 phase; 50/60/hertz
Electrical Controls:	PLC
Enclosure:	NEMA12 or NEMA 4
Software Features:	

- Adjustable Machine Parameters
- Adjustable Agitator Speed
- Adjustable Auger Drive Speed
- Adjustable Acceleration and Deceleration
- Auger Jog
- Hopper Empty
- Recycle Timers
- 99 product recipes

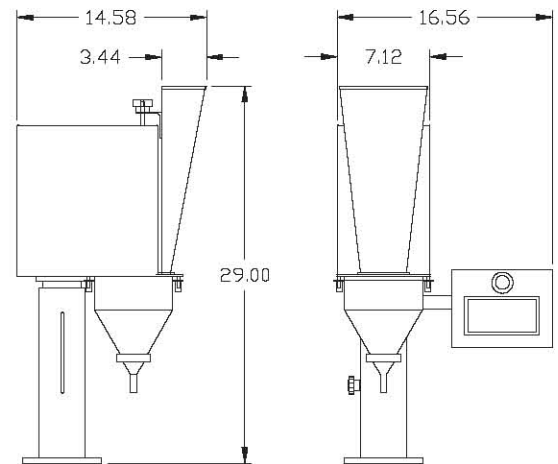

nano-Filler

fill head

Auger Drive:	Brushless Servo Motor, Direct Drive Rated for 0.10 hp (100 W)
Auger Speed:	1 to 2000 RPM
Agitation Motor:	1/20 hp Variable Speed Motor
Agitation Drive:	Polyurethane Flat Chain
Construction:	Polished Stainless Steel Product Contact Parts and Head Cover

speed and accuracy

Filling Speed:	10 to 100 doses per minute
Filling Accuracy:	± 1% to 3% of net weight

options

Automation:	Please call for more information.
Level Control:	Signals Infeed and Controls Product Level
Balances:	For Fill-by-weight Operation
Infeed:	Extension Hopper agitation and product infeed equipment

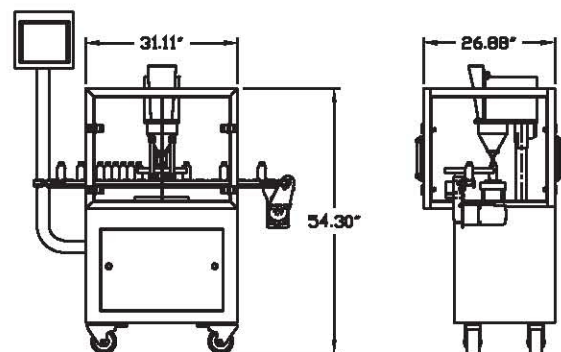

**nano-Filler with
automation package**

BUSCH MACHINERY

Over 30 Years of Applications Expertise

800-840-9573 INTL 520-777-3360

EMAIL: sales@busch-machinery.com

WEBSITE: <http://busch-machinery.com>