

PF -28

Product Spec Sheet

The Model PF-28RCM is an automatic, rotary continuous motion filling system; its modular design allows for high speed filling of powder and granular products.



The Model PF-28 Rotary Continuous Motion Filler can fill virtually any rigid container at speeds up to 350 cpm.

This rugged fill system features a rotary funnel turret for high speed filling, heavy duty SST base, and Lexan safety enclosure.

Available options include: vacuum assist on the funnels to assist product flow into the container, orbital vibration on the funnel turret, vibrating rail to assist product settling in the container, checkweigher feedback package for automatic adjustment of fill weights.

PF-28

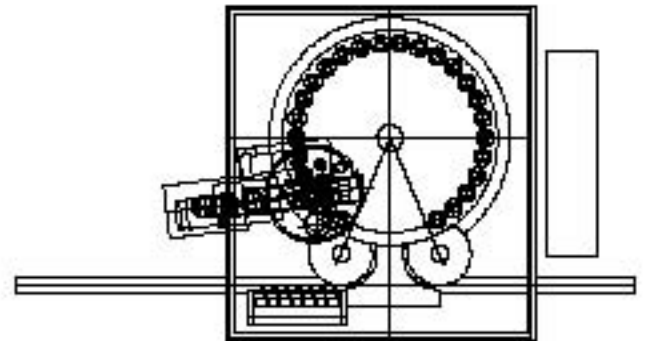
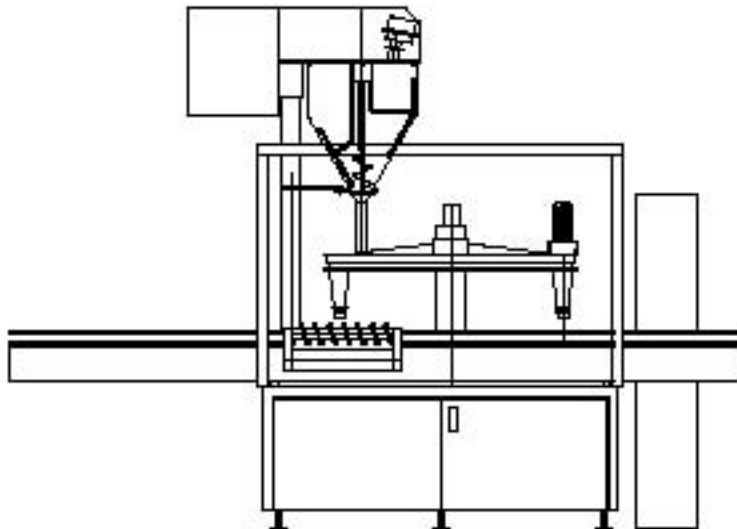

Products Filled:	Powders and Granules
Fill Speed:	60-350 Fills/minute
Containers Filled:	Bottles, Jars and Boxes
Fill Accuracy:	+/- 1 - 3 %
Fill Range:	0.5 grams to 5 kg
Operation:	Automatic
Hopper Capacity:	2 to 5 cubic feet, depending on application
Construction:	All stainless steel product contact parts with NEMA 12 controls. Also available with NEMA 4X controls and sanitary construction.
Physical Size:	8' x 12' x 8.5'
Cleaning/Changeover Time:	40-60 minutes
Availability:	12-18 weeks
Budgetary Pricing:	\$110,000 to \$300,000*
Special Features:	Available with servo drive or clutch/brake. Turnkey systems available. CE Mark.

BUSCH MACHINERY

Over 30 Years of Applications Expertise

800-840-9573 INTL 520-777-3360

EMAIL: sales@busch-machinery.com

WEBSITE: <http://busch-machinery.com>