

# BUSCH MACHINERY

## K50 Compact

### LABEL APPLICATOR

30 m/min speed  
Label position accuracy of +/- 1mm  
Labels up to 115mm wide  
With mounting arm for easy installation and orientation  
Ready for external printer use  
Ideal for automatic labeling of products on production lines



**Busch Machinery, Inc.**  
727 E. 20th St.  
Tucson, AZ 85719  
Phone: 800-840-9573 (USA Only)  
Fax: 800-840-6270 (USA Only)  
Phone 520-777-3360  
Fax: 520-777-3369  
E-mail: [sales.inquiries@busch-machinery.com](mailto:sales.inquiries@busch-machinery.com)

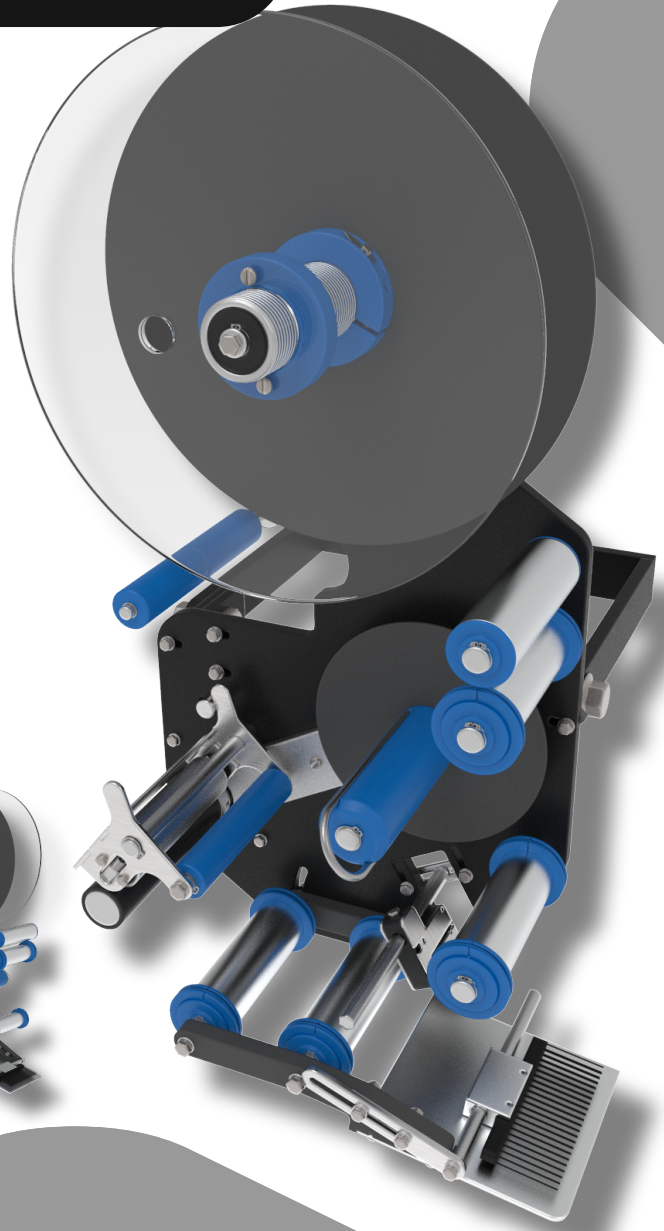

Internal memory to save up to 50 different label formats  
Numeric keypad with LCD display

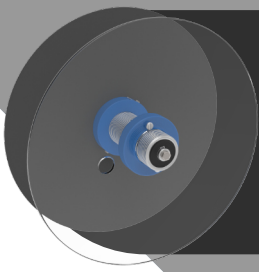

Rolls up to 300mm in diameter  
76mm inner diameter

The K50 compact head is reversible so it can be changed from left to right configuration and vice versa in the field

# BUSCH MACHINERY

## K50 Compact

LABEL APPLICATOR

## DIMENSIONS

Right Version

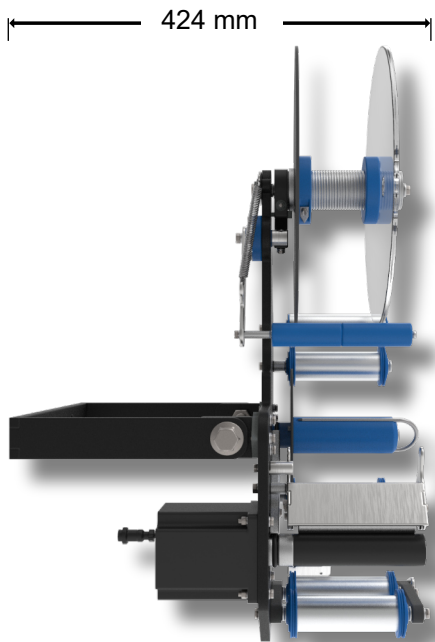
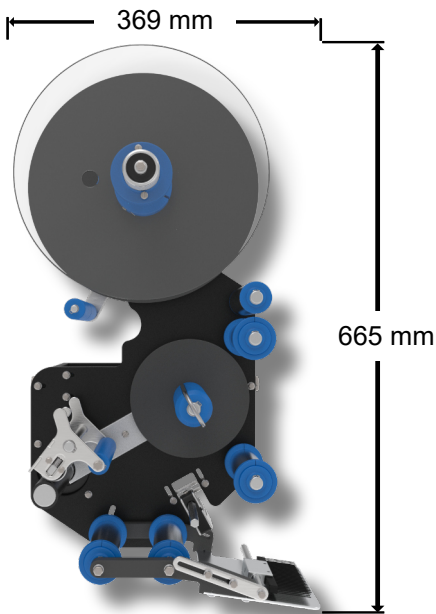

Left Version

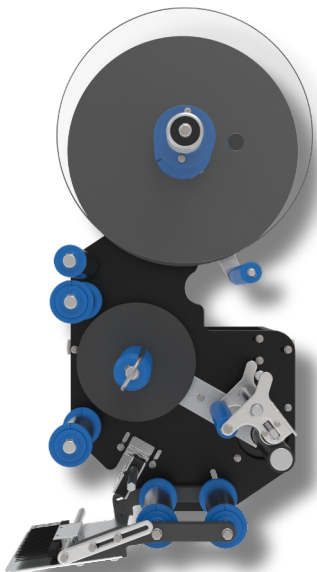

**Busch Machinery, Inc.**  
727 E. 20th St.  
Tucson, AZ 85719  
Phone: 800-840-9573 (USA Only)  
Fax: 800-840-6270 (USA Only)  
Phone 520-777-3360  
Fax: 520-777-3369  
E-mail: [sales.inquiries@busch-machinery.com](mailto:sales.inquiries@busch-machinery.com)

## K50 Compact

LABEL APPLICATOR

## SPECS

<b>Labeling speed</b>	Up to 30 m/min
<b>Label width</b>	Up to 115 mm
<b>Paper roll outer diameter</b>	Up to 300 mm
<b>Paper roll inner diameter</b>	76 mm
<b>Power supply</b>	350 W 220V-240V, 50Hz* 110V-120V, 60Hz*
<b>Weight (kg)</b>	25
<b>Dimensions (mm)</b>	784 x 581 x 426



**Busch Machinery, Inc.**  
727 E. 20th St.  
Tucson, AZ 85719  
Phone: 800-840-9573 (USA Only)  
Fax: 800-840-6270 (USA Only)  
Phone 520-777-3360  
Fax: 520-777-3369  
E-mail: [sales.inquiries@busch-machinery.com](mailto:sales.inquiries@busch-machinery.com)

\* To change the supply voltage contact us