

LCW 50/200 R

ROLLER WRAPPING LABELING SYSTEM

Packaging from 15mm to 150mm in diameter¹
Possibility of orienting the label on the product
Multiple labels in a single container
Built in stainless steel



32 product memories
Numeric keypad with LCD display

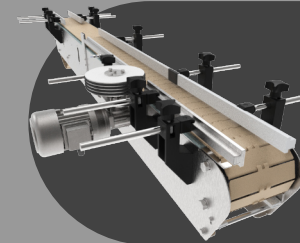

Variable speed with automatic synchronization
Adjustable side guides



¹ The product to label must be able to keep itself stable. For unstable products contact us.

LCW 50/200 R

ROLLER WRAPPING LABELING SYSTEM

DIMENSIONS

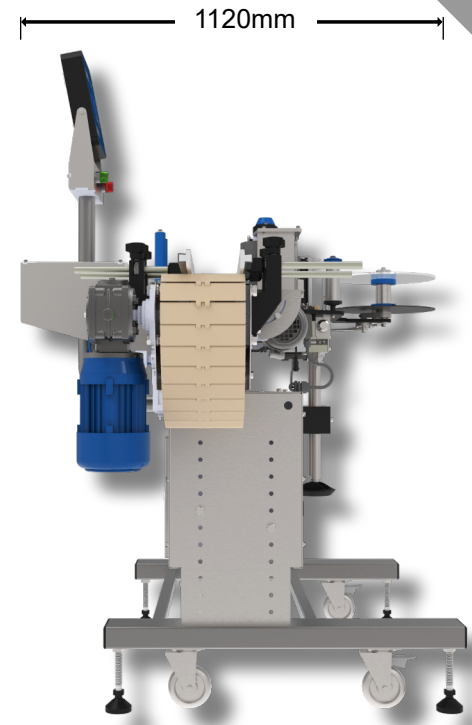
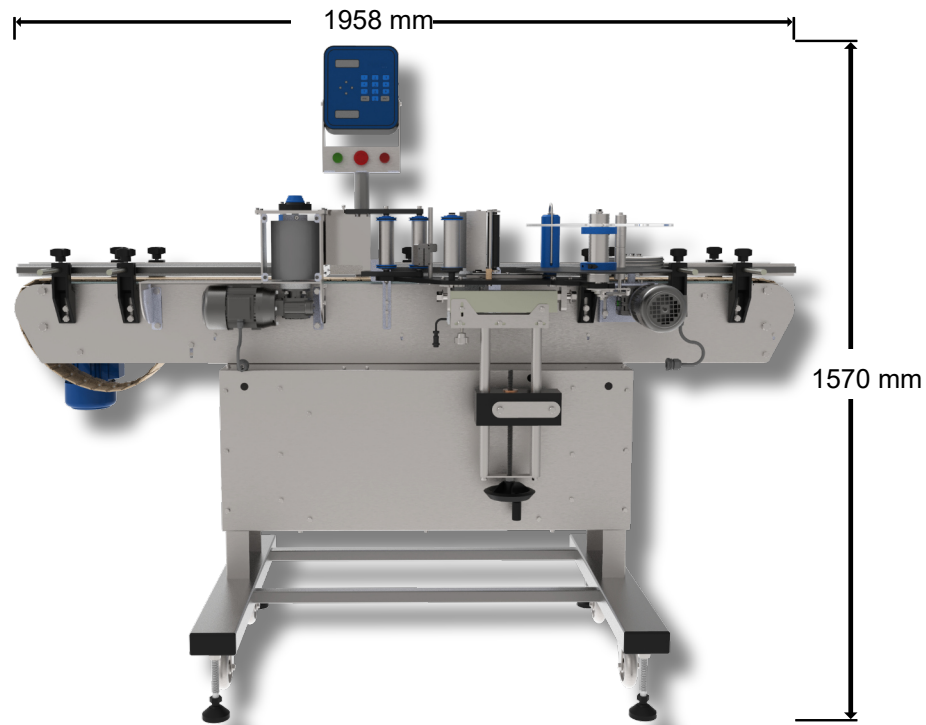

Left Version

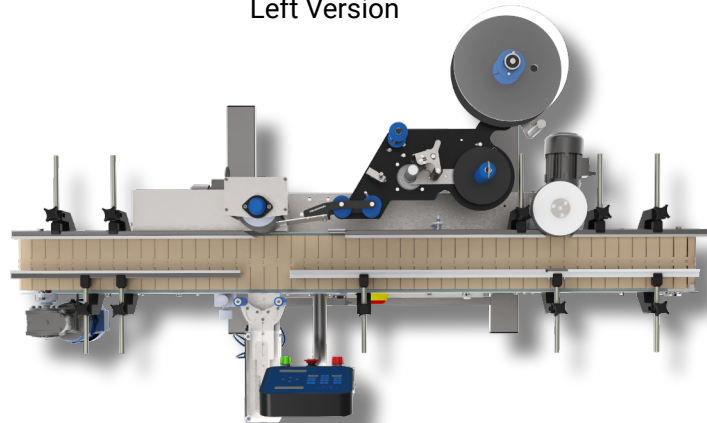

Right Version

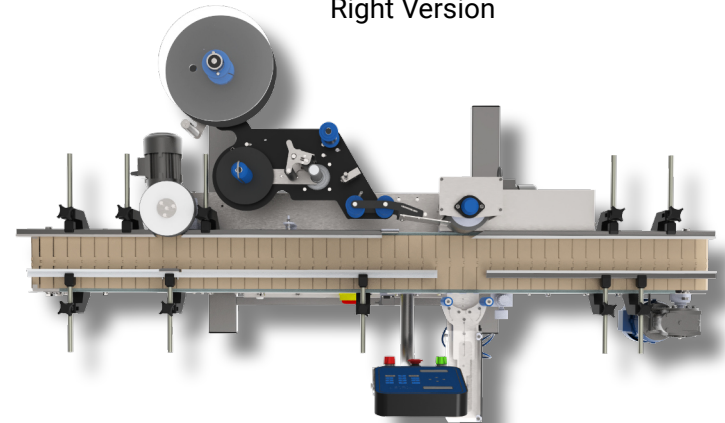

LCW 50/200

ROLLER WRAPPING LABELING SYSTEM

SPECS

Cabezas compatibles	K50, K200, KFLEX
Labeling capacity	Up to 40 labels/min depending on label length
Labeling speed	1-30 m / min. Product is retained while label is dispensed
Label width	Up to 115 or 170 mm depending on the labeling head
Largo de etiqueta	Up to 280 mm
Paper roll inner diameter	76 mm
Paper roll outer diameter	Up to 300 mm
Transport width	152.4 mm (6 in) standard. Possibility of customized transport widths on request
Product Diameter	15-150 mm standard. Possibility of larger diameters on request
Power supply	1.5 kVA 220V-240V, 50Hz* 110V-120V, 60Hz*
Weight (kg)	200
Dimensions (mm)	1958 x 1096 x 1567

* The equipment is only compatible with one type of electrical supply. You must select the appropriate power supply when placing your order.