

BUSCH MACHINERY

KFLEX

LABEL APPLICATOR
WITH TTO PRINTER

30 m/min speed
Label position accuracy of ± 1 mm
Labels up to 115mm wide
With mounting arm for easy installation and orientation
Ideal for automatic labeling of products on production lines



Busch Machinery, Inc.
727 E. 20th St.
Tucson, AZ 85719
Phone: 800-840-9573 (USA Only)
Fax: 800-840-6270 (USA Only)
Phone 520-777-3360
Fax: 520-777-3369
E-mail: sales.inquiries@busch-machinery.com

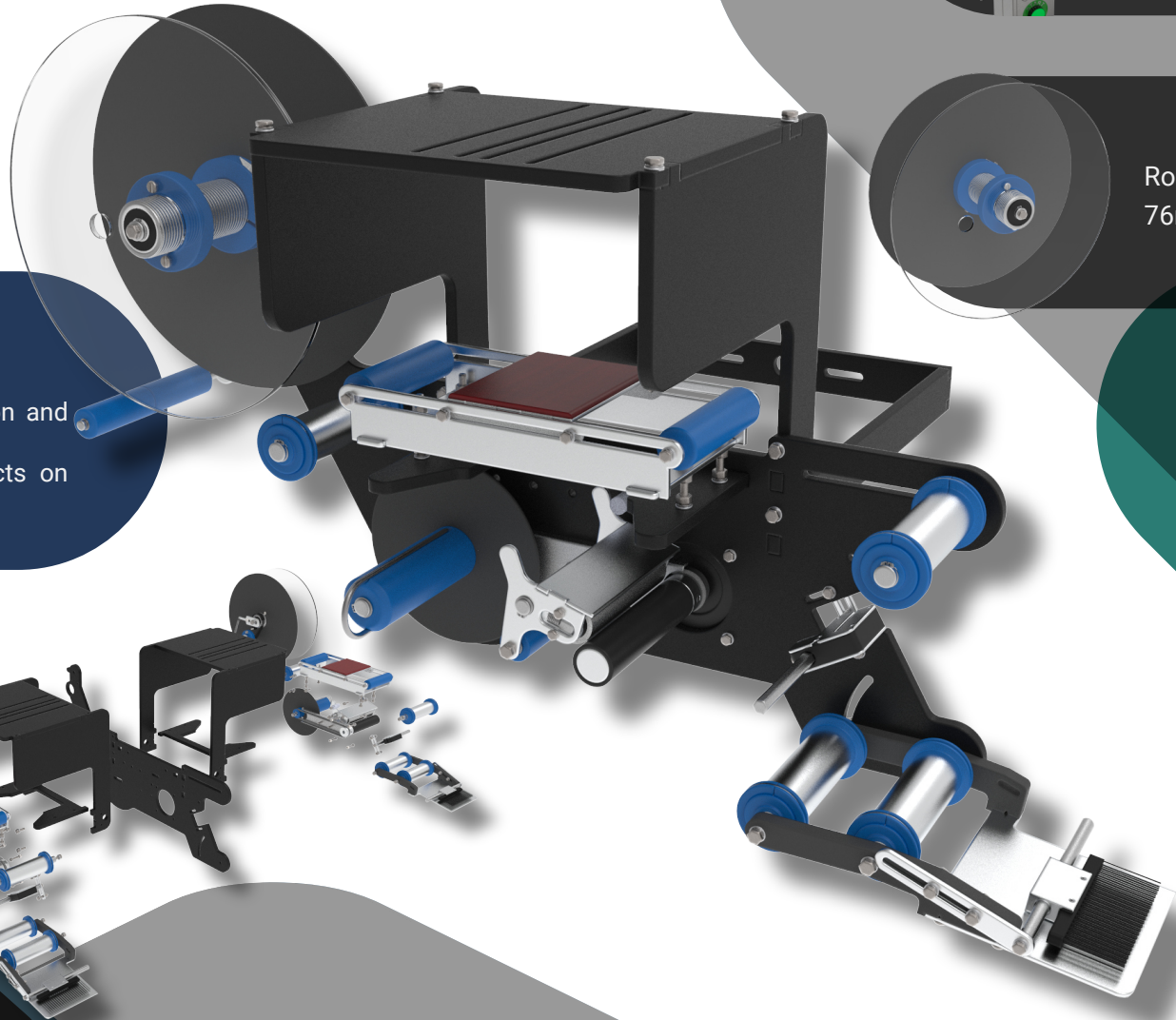

Internal memory to save up to 50 different label formats
Numeric keypad with LCD display

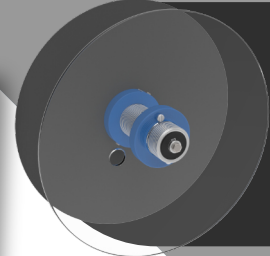

Rolls up to 300mm in diameter
76mm inner diameter

The KFLEX head is reversible so it can be changed from left to right configuration and vice versa in the field

BUSCH MACHINERY

KFLEX

LABEL APPLICATOR
WITH TTO PRINTER

DIMENSIONS

Right Version

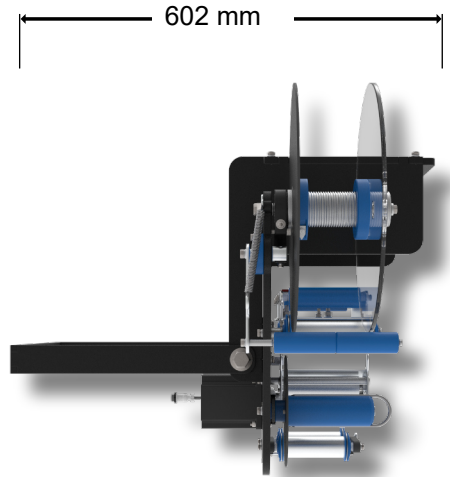
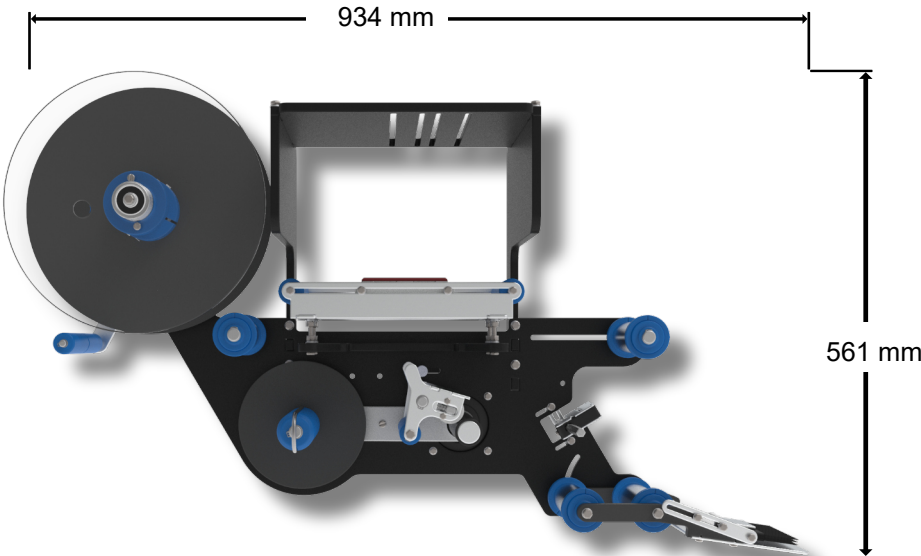

Left Version

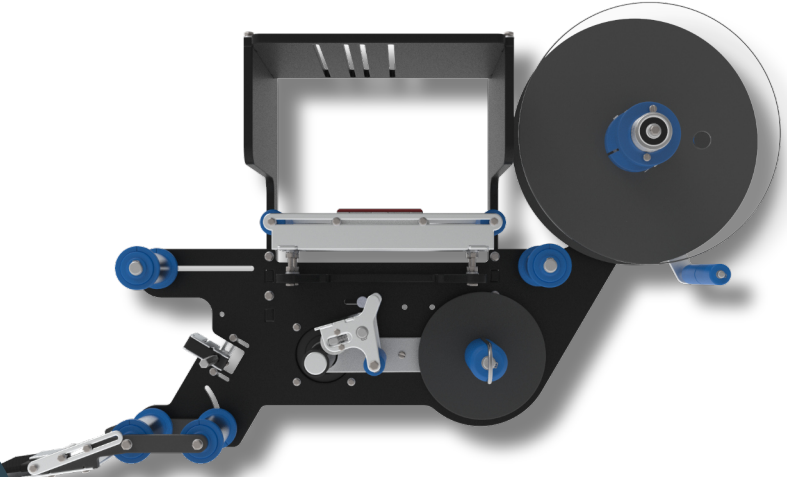

Busch Machinery, Inc.
727 E. 20th St.
Tucson, AZ 85719
Phone: 800-840-9573 (USA Only)
Fax: 800-840-6270 (USA Only)
Phone 520-777-3360
Fax: 520-777-3369
E-mail: sales.inquiries@busch-machinery.com

KFLEX

LABEL APPLICATOR
WITH TTO PRINTER

SPECS

Labeling speed	Up to 30 m/min
Label width	Up to 115 mm
Paper roll outer diameter	Up to 300 mm
Paper roll inner diameter	76 mm
Power supply	350 W 220V-240V, 50Hz* 110V-120V, 60Hz*
Weight (kg)	25
Dimensions (mm)	934 x 561 x 602



Busch Machinery, Inc.

727 E. 20th St.

Tucson, AZ 85719

Phone: 800-840-9573 (USA Only)

Fax: 800-840-6270 (USA Only)

Phone 520-777-3360

Fax: 520-777-3369

E-mail: sales.inquiries@busch-machinery.com

* To change the supply voltage contact us