

BUSCH MACHINERY

UW

UNSTABLE CYLINDRICAL LABELING SYSTEM

Containers from 9.5mm to 50mm in diameter
Speed of 150 products per minute¹
Built in stainless steel

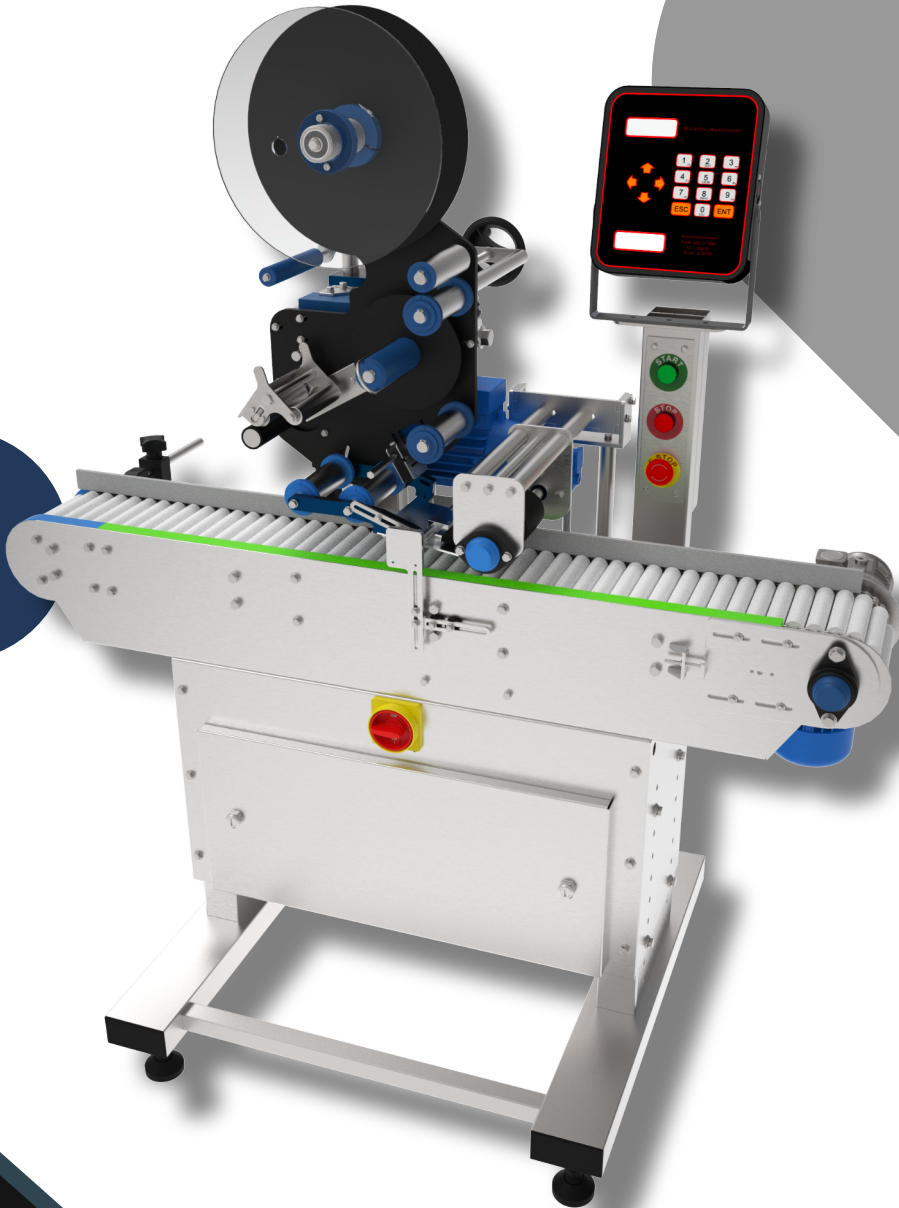

32 product memories
Numeric keypad with LCD display

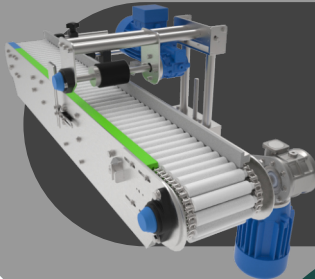

Variable speed with automatic synchronization
Wrap roller



Busch Machinery, Inc.
727 E. 20th St.
Tucson, AZ 85719
Phone: 800-840-9573 (USA Only)
Fax: 800-840-6270 (USA Only)
Phone 520-777-3360
Fax: 520-777-3369
E-mail: sales.inquiries@busch-machinery.com

¹ It depends on the size of the container and label.

BUSCH MACHINERY

UW

UNSTABLE CYLINDRICAL LABELING SYSTEM

DIMENSIONS

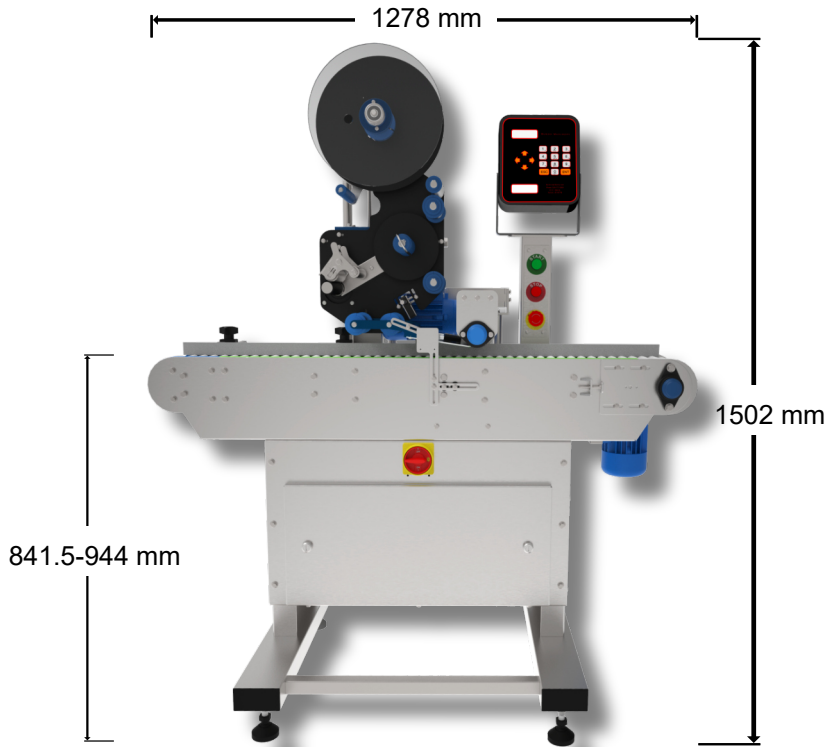

Left Version

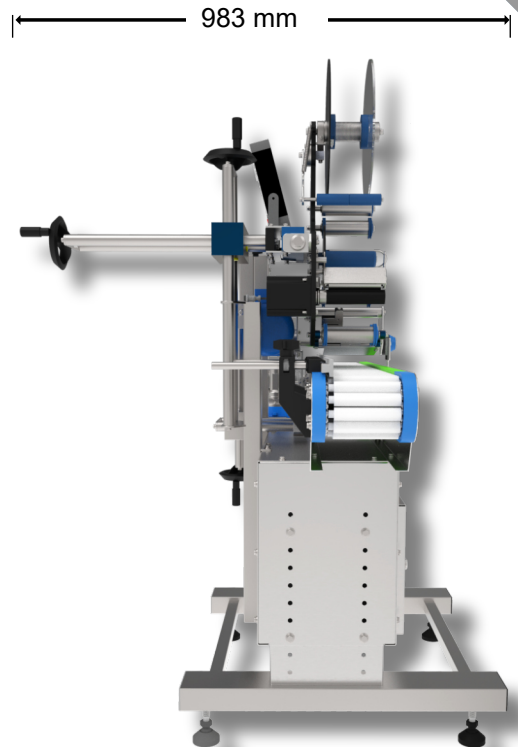

Right Version

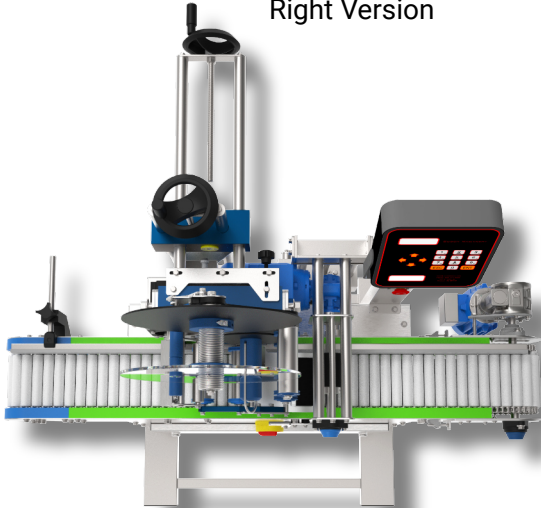
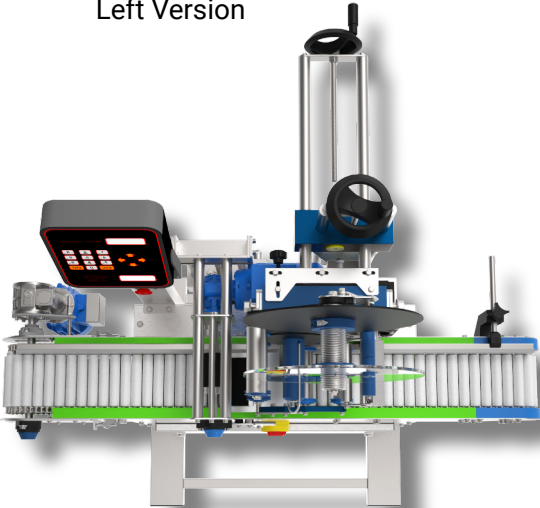

Busch Machinery, Inc.
727 E. 20th St.
Tucson, AZ 85719
Phone: 800-840-9573 (USA Only)
Fax: 800-840-6270 (USA Only)
Phone 520-777-3360
Fax: 520-777-3369
E-mail: sales.inquiries@busch-machinery.com

UW

UNSTABLE CYLINDRICAL LABELING SYSTEM

SPECS

Compatible labeling heads	K50, K200, KFLEX
Labeling speed	1-30 m/min
Ancho de etiqueta	Up to 115 or 170 mm depending on the labeling head
Transport width	120 mm standard. Possibility of customized transport widths on request
Paper roll outer diameter	75 mm
Paper roll inner diameter	300 mm
Product diameter	9.5-50 mm
Power supply	1.5 kVA 220V-240V, 50Hz* 110V-120V, 60Hz*
Weight (kg)	200
Dimensions (mm)	1278 x 1502 x 983

* The equipment is only compatible with one type of electrical supply. You must select the appropriate power supply when placing your order.



Busch Machinery, Inc.
727 E. 20th St.
Tucson, AZ 85719
Phone: 800-840-9573 (USA Only)
Fax: 800-840-6270 (USA Only)
Phone 520-777-3360
Fax: 520-777-3369
E-mail: sales.inquiries@busch-machinery.com